



HIGH

EFFICIENT GEARLESS
TRACTION MACHINE

2025





ABOUT US

APSON is an Indian multinational elevator component manufacturing company. With the vision of developing the safest and premium range of power-efficient elevator traction machines to fulfill the needs of the elevator industry; APSON was established in 2016 by the former promoter Mr. Arvind Panchal of a 60-year-old Indian multinational conglomerate Rabatex Group.

With 30 years of experience in the mechanical and automation industry; APSON signed a non-disclosable joint venture in 2016 for developing and manufacturing elevator traction machines. In 2018; APSON launched their complete range of elevator gearless traction machine as well as became world's first company to offer 4 Year Warranty on it.

APSON is the only company in India to have elevator motors up to 48 poles. Having a capacity range up to 7000 kg and speed up to 12.0 m/s our process of innovation in ultra-high-speed and heavy capacity elevator gearless traction machines is going on.

Under the bright foresight of Mr. Arvind Panchal (Founder – APSON MOTOR (INDIA) PRIVATE LIMITED), the company is achieving the milestones of success in providing highly efficient and qualitative elevator gearless traction machines across the globe.

Another pillar behind the success of APSON is Mr. Hiren Panchal (Managing Director – APSON MOTOR (INDIA) PRIVATE LIMITED) whose productive ideas, execution of business strategies, ways of promoting the adaption of new technology; has brought the revolution in the elevators Industry.

With our expertise in engineering and maintaining quality; we aim to keep the elevator and escalator industry safe and to ensure the safety of all passengers traveling into it.





INFRASTRUCTURE

Spreading over 20,000 square meter area with a total employment of 100+ hands directly or indirectly as well as equipped with state of art manufacturing facilities; APSON have one of the most advance production unit for elevator traction machine in the out skirts of Ahmedabad Metro.

APSON have dedicated assembly line for elevator gearless traction machines having a production capacity of 24,000 motors per annum.

Equipped with advance assembly line and testing facilities, such as automatic stator testing, load testing, over load testing, noise testing and many more; we make sure that we produce the safest products for our end users.

The company has envisaged further major investment for product development up-gradation, renovation and modernization of production and testing facilities as required from time to time.





Production and Quality Control Facilities



Advanced assembly line for traction machine

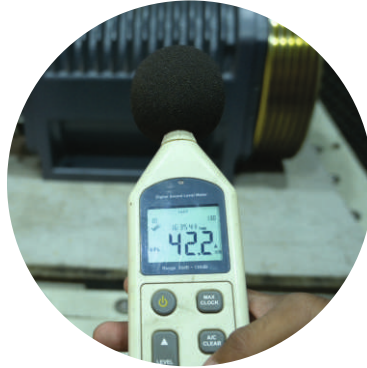

Noise proof room for noise test of PMSM



Dust proof room for assembly of PMSM



CNC turning center



CNC vertical milling center



CNC horizontal machining center



Automatic coil winding machine



On-load PMSM testing



On-load PMSM analysis



ES272-408

HOME ELEVATOR EXPERT

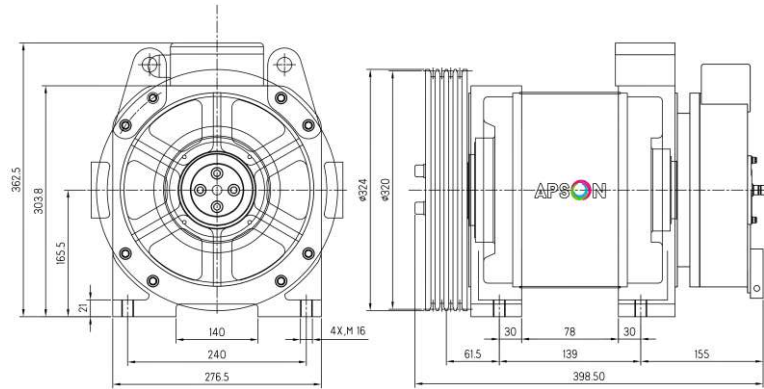

ECO STRONG ELEVATOR GEARLESS TRACTION MACHINE FOR HOME ELEVATOR

ROPING	2:1	STATIC LOAD	1500 kg
BALANCING	50%	MACHINE WEIGHT	130 kg*
DUTY CYCLE	S5-40%	BRAKE VOLTAGE	DC110V
STARTS / HOUR	180 ST/H	INSULATION CLASS	F
GROOVE TYPE	UNDERCUT "U"	GROOVE β'	90°
IP PROTECTION	IP41	GROOVE γ	30°
POLE	24	WARRANTY	7 YEAR*

SPECIFICATION SHEET

MODEL	RATED VOLTAGE	CAPACITY	CABIN SPEED	RATED OUTPUT POWER	RATED CURRENT	RATED SPEED	FREQ.	SHEAVE DIA.	TORQUE	GROOVE DETAILS
	V	kg	m/s	kW	A	rpm	Hz	mm	N.m.	
ES272	AC220	272	0.50	1.00	6.00	95	19.1	Ø200	100	4 × Ø8 × 12
ES272	AC220	272	1.00	2.00	10.0	191	38.2	Ø200	100	4 × Ø8 × 12
ES272	AC380	272	0.50	1.00	3.00	95	19.1	Ø200	100	4 × Ø8 × 12
ES272	AC380	272	1.00	2.00	6.00	191	38.2	Ø200	100	4 × Ø8 × 12
ES408	AC220	408	0.50	1.20	7.00	95	19.1	Ø200	122	4 × Ø8 × 12
ES408	AC220	408	1.00	2.40	13.0	191	38.2	Ø200	122	4 × Ø8 × 12
ES408	AC220	408	0.50	1.20	7.00	80	15.9	Ø240	147	4 × Ø8 × 12
ES408	AC220	408	1.00	2.40	13.0	159	31.8	Ø240	147	4 × Ø8 × 12
ES408	AC380	408	0.50	1.20	4.00	95	19.1	Ø200	122	4 × Ø8 × 12
ES408	AC380	408	1.00	2.40	8.00	191	38.2	Ø200	122	4 × Ø8 × 12
ES408	AC380	408	0.50	1.20	4.00	80	15.9	Ø240	147	4 × Ø8 × 12
ES408	AC380	408	1.00	2.40	8.00	159	31.8	Ø240	147	4 × Ø8 × 12



ECO STRONG ES450

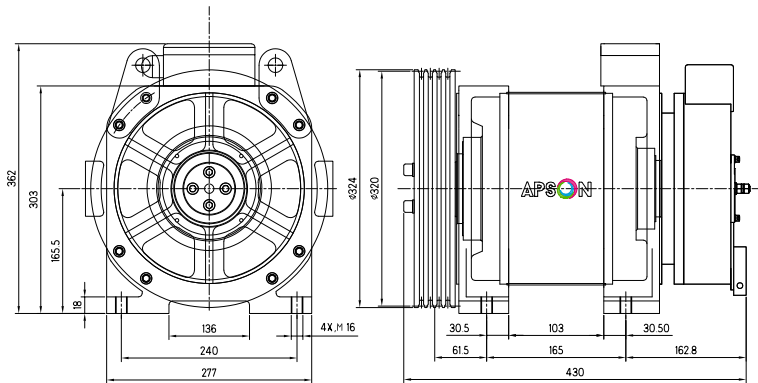
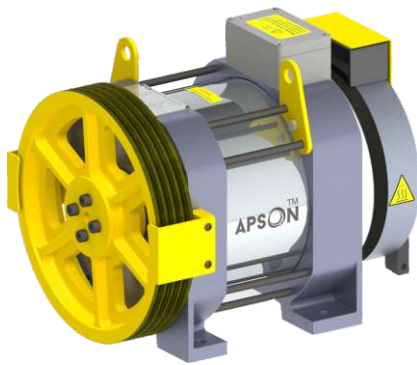

ECO STRONG PERMANENT MAGNET SYNCHRONOUS ELEVATOR GEARLESS TRACTION MACHINE

ROPING	2:1	STATIC LOAD	2500 kg
BALANCING	50%	MACHINE WEIGHT	145 kg*
DUTY CYCLE	S5-40%	BRAKE VOLTAGE	DC110V
STARTS / HOUR	180 ST/H	INSULATION CLASS	F
GROOVE TYPE	UNDERCUT "U"	GROOVE β'	90°
IP PROTECTION	IP41	GROOVE γ	30°
POLE	24	WARRANTY	2 YEAR*

SPECIFICATION SHEET

MODEL	RATED VOLTAGE	CAPACITY	CABIN SPEED	RATED OUTPUT POWER	RATED CURRENT	RATED SPEED	FREQ.	SHEAVE DIA.	TORQUE	GROOVE DETAILS
	V	kg	m/s	kW	A	rpm	Hz	mm	N.m.	
ES450	AC220	450	0.50	1.60	10.0	60	11.9	Ø320	249	4 × Ø8 × 12
ES450	AC220	450	0.75	2.30	16.0	90	17.9	Ø320	249	4 × Ø8 × 12
ES450	AC220	450	1.00	3.10	16.0	119	23.8	Ø320	249	4 × Ø8 × 12
ES450	AC380	450	0.50	1.60	5.50	60	11.9	Ø320	249	4 × Ø8 × 12
ES450	AC380	450	0.75	2.30	8.50	90	17.9	Ø320	249	4 × Ø8 × 12
ES450	AC380	450	1.00	3.10	8.50	119	23.8	Ø320	249	4 × Ø8 × 12
ES450	AC380	450	1.25	3.90	12.5	149	29.8	Ø320	249	4 × Ø8 × 12
ES450	AC380	450	1.50	4.70	12.5	179	35.8	Ø320	249	4 × Ø8 × 12



ECO STRONG ES544

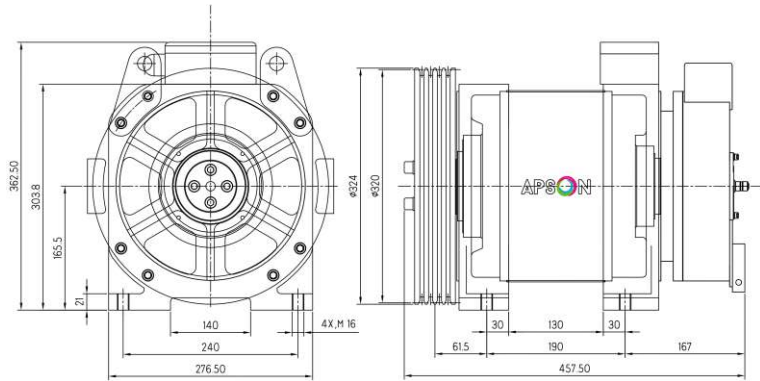
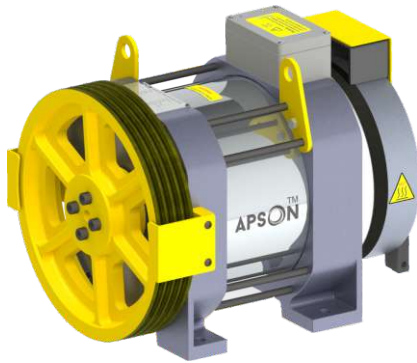

ECO STRONG PERMANENT MAGNET SYNCHRONOUS ELEVATOR GEARLESS TRACTION MACHINE

ROPING	2:1	STATIC LOAD	2500 kg
BALANCING	50%	MACHINE WEIGHT	160 kg*
DUTY CYCLE	S5-40%	BRAKE VOLTAGE	DC110V
STARTS / HOUR	180 ST/H	INSULATION CLASS	F
GROOVE TYPE	UNDERCUT "U"	GROOVE β'	90°
IP PROTECTION	IP41	GROOVE γ	30°
POLE	24	WARRANTY	2 YEAR*

SPECIFICATION SHEET

MODEL	RATED VOLTAGE	CAPACITY	CABIN SPEED	RATED OUTPUT POWER	RATED CURRENT	RATED SPEED	FREQ.	SHEAVE DIA.	TORQUE	GROOVE DETAILS
	V	kg	m/s	kW	A	rpm	Hz	mm	N.m.	
ES544	AC380	544	0.50	2.00	7.00	80	15.9	Ø240	218	4 × Ø8 × 12
ES544	AC380	544	1.00	3.70	9.00	159	31.8	Ø240	218	4 × Ø8 × 12
ES544	AC380	544	1.25	4.50	13.0	199	39.8	Ø240	218	4 × Ø8 × 12
ES544	AC380	544	1.50	5.60	17.0	239	47.7	Ø240	218	4 × Ø8 × 12
ES544	AC380	544	0.50	2.00	7.00	60	11.9	Ø320	300	4 × Ø8 × 12
ES544	AC380	544	1.00	3.70	9.00	119	23.8	Ø320	300	4 × Ø8 × 12
ES544	AC380	544	1.25	4.50	13.0	149	29.8	Ø320	300	4 × Ø8 × 12
ES544	AC380	544	1.50	5.60	17.0	179	35.8	Ø320	300	4 × Ø8 × 12



IR SERIES IR630-680

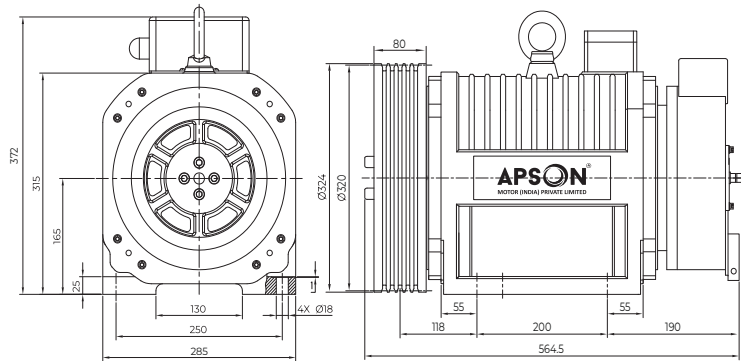

INNER ROTOR PERMANENT MAGNET SYNCHRONOUS ELEVATOR GEARLESS TRACTION MACHINE

ROPING	2:1	STATIC LOAD	3000 kg
BALANCING	50%	MACHINE WEIGHT	225 kg*
DUTY CYCLE	S5-40%	BRAKE VOLTAGE	DC110V
STARTS / HOUR	240 ST/H	INSULATION CLASS	F / H
GROOVE TYPE	UNDERCUT "U"	GROOVE β'	90°
IP PROTECTION	IP41	GROOVE γ	30°
POLE	24	WARRANTY	5 YEAR*

SPECIFICATION SHEET

MODEL	RATED VOLTAGE	CAPACITY	CABIN SPEED	RATED OUTPUT POWER	RATED CURRENT	RATED SPEED	FREQ.	SHEAVE DIA.	TORQUE	GROOVE DETAILS
	V	kg	m/s	kW	A	rpm	Hz	mm	N.m.	
IR630	AC380	630	0.50	2.10	7.00	60	11.9	Ø320	336	5 × Ø8 × 12
IR630	AC380	630	1.00	4.20	14.0	119	23.9	Ø320	336	5 × Ø8 × 12
IR630	AC380	630	1.25	5.30	14.0	149	29.8	Ø320	336	5 × Ø8 × 12
IR630	AC380	630	1.50	6.30	19.0	179	35.8	Ø320	336	5 × Ø8 × 12
IR630	AC380	630	1.75	7.40	19.0	209	41.8	Ø320	336	5 × Ø8 × 12
IR630	AC380	630	2.00	8.40	22.0	239	47.7	Ø320	336	5 × Ø8 × 12
IR680	AC380	680	0.50	2.30	7.00	60	11.9	Ø320	363	5 × Ø8 × 12
IR680	AC380	680	1.00	4.50	14.0	119	23.8	Ø320	363	5 × Ø8 × 12
IR680	AC380	680	1.25	5.70	14.0	149	29.8	Ø320	363	5 × Ø8 × 12
IR680	AC380	680	1.50	6.80	19.0	179	35.8	Ø320	363	5 × Ø8 × 12
IR680	AC380	680	1.75	7.90	19.0	209	41.8	Ø320	363	5 × Ø8 × 12
IR680	AC380	680	2.00	9.10	22.0	239	47.7	Ø320	363	5 × Ø8 × 12



IR SERIES IR800-884

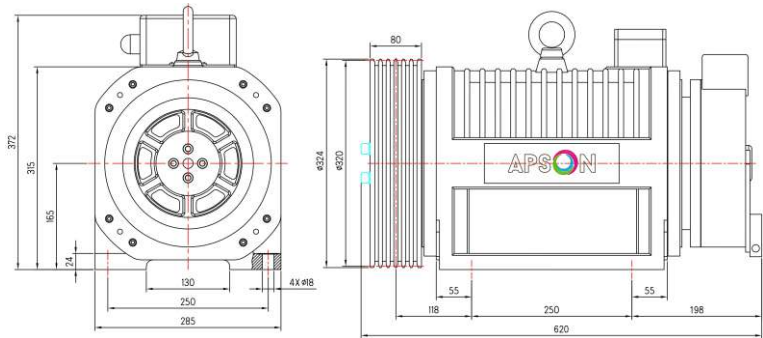
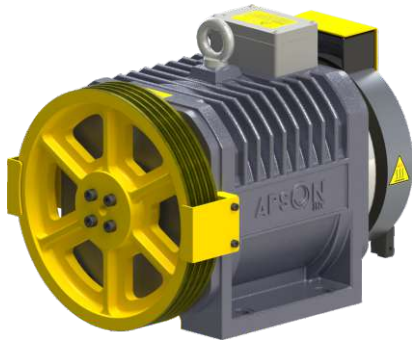

INNER ROTOR PERMANENT MAGNET SYNCHRONOUS ELEVATOR GEARLESS TRACTION MACHINE

ROPING	2:1	STATIC LOAD	3000 kg
BALANCING	50%	MACHINE WEIGHT	250 kg*
DUTY CYCLE	S5-40%	BRAKE VOLTAGE	DC110V
STARTS / HOUR	240 ST/H	INSULATION CLASS	F / H
GROOVE TYPE	UNDERCUT "U"	GROOVE β'	90°
IP PROTECTION	IP41	GROOVE γ	30°
POLE	24	WARRANTY	5 YEAR*

SPECIFICATION SHEET

MODEL	RATED VOLTAGE	CAPACITY	CABIN SPEED	RATED OUTPUT POWER	RATED CURRENT	RATED SPEED	FREQ.	SHEAVE DIA.	TORQUE	GROOVE DETAILS
	V	kg	m/s	kW	A	rpm	Hz	mm	N.m.	
IR800	AC380	800	0.50	2.40	8.00	60	11.9	Ø320	400	6 × Ø8 × 12
IR800	AC380	800	1.00	4.80	15.0	119	23.9	Ø320	400	6 × Ø8 × 12
IR800	AC380	800	1.25	6.00	15.0	149	29.8	Ø320	400	6 × Ø8 × 12
IR800	AC380	800	1.50	7.20	20.0	179	35.8	Ø320	400	6 × Ø8 × 12
IR800	AC380	800	1.75	8.40	20.0	209	41.8	Ø320	400	6 × Ø8 × 12
IR800	AC380	800	2.00	9.60	23.0	239	47.7	Ø320	400	6 × Ø8 × 12
IR884	AC380	884	0.50	2.60	8.00	60	11.9	Ø320	424	6 × Ø8 × 12
IR884	AC380	884	1.00	5.30	16.0	119	23.8	Ø320	424	6 × Ø8 × 12
IR884	AC380	884	1.25	6.60	16.0	149	29.8	Ø320	424	6 × Ø8 × 12
IR884	AC380	884	1.50	7.90	21.0	179	35.8	Ø320	424	6 × Ø8 × 12
IR884	AC380	884	1.75	9.30	21.0	209	41.8	Ø320	424	6 × Ø8 × 12
IR884	AC380	884	2.00	10.6	24.0	239	47.7	Ø320	424	6 × Ø8 × 12



IR SERIES IR1088-1360

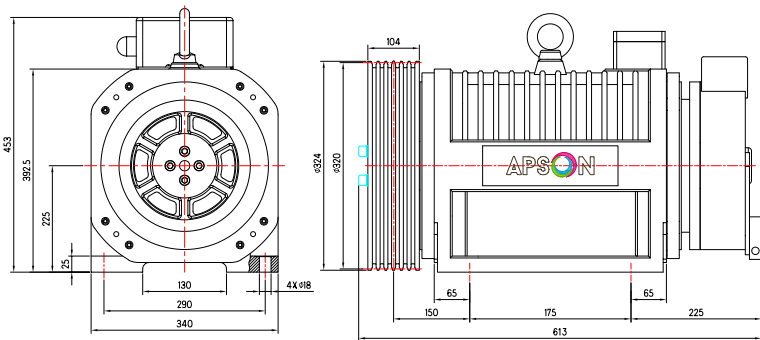

INNER ROTOR PERMANENT MAGNET SYNCHRONOUS ELEVATOR GEARLESS TRACTION MACHINE

ROPING	2:1	STATIC LOAD	4500 kg
BALANCING	50%	MACHINE WEIGHT	300 kg*
DUTY CYCLE	S5-40%	BRAKE VOLTAGE	DC110V
STARTS / HOUR	240 ST/H	INSULATION CLASS	F / H
GROOVE TYPE	UNDERCUT "U"	GROOVE β'	90°
IP PROTECTION	IP41	GROOVE γ	30°
POLE	24	WARRANTY	5 YEAR*

SPECIFICATION SHEET

MODEL	RATED VOLTAGE	CAPACITY	CABIN SPEED	RATED OUTPUT POWER	RATED CURRENT	RATED SPEED	FREQ.	SHEAVE DIA.	TORQUE	GROOVE DETAILS
	V	kg	m/s	kW	A	rpm	Hz	mm	N.m.	
IR1088	AC380	1088	0.50	3.30	8.00	60	11.9	Ø320	522	8 × Ø8 × 12
IR1088	AC380	1088	1.00	6.50	19.0	119	23.8	Ø320	522	8 × Ø8 × 12
IR1088	AC380	1088	1.25	8.20	19.0	149	29.8	Ø320	522	8 × Ø8 × 12
IR1088	AC380	1088	1.50	9.80	27.0	179	35.8	Ø320	522	8 × Ø8 × 12
IR1088	AC380	1088	1.75	11.4	27.0	209	41.8	Ø320	522	8 × Ø8 × 12
IR1088	AC380	1088	2.00	13.0	31.0	239	47.7	Ø320	522	8 × Ø8 × 12
IR1088	AC380	1088	2.50	16.3	39.0	298	59.7	Ø320	522	8 × Ø8 × 12
IR1360	AC380	1360	0.50	4.10	11.0	60	11.9	Ø320	652	8 × Ø8 × 12
IR1360	AC380	1360	1.00	8.20	22.0	119	23.8	Ø320	652	8 × Ø8 × 12
IR1360	AC380	1360	1.25	10.2	28.0	149	29.8	Ø320	652	8 × Ø8 × 12
IR1360	AC380	1360	1.50	12.2	30.0	179	35.8	Ø320	652	8 × Ø8 × 12
IR1360	AC380	1360	2.00	16.3	40.0	239	47.7	Ø320	652	8 × Ø8 × 12



IR SERIES IR1500-2175

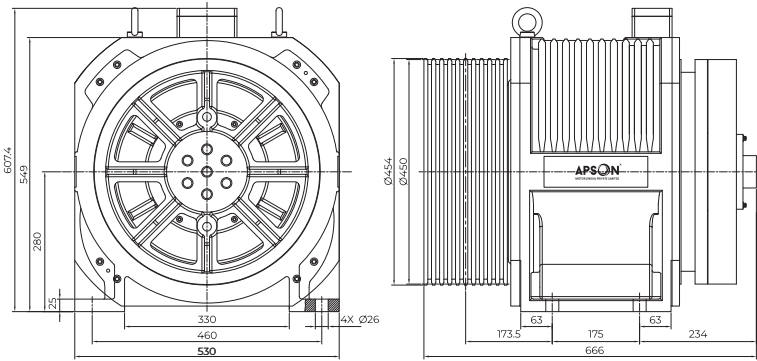

INNER ROTOR PERMANENT MAGNET SYNCHRONOUS ELEVATOR GEARLESS TRACTION MACHINE

ROPING	2:1	STATIC LOAD	6000 kg
BALANCING	50%	MACHINE WEIGHT	600 kg*
DUTY CYCLE	S5-40%	BRAKE VOLTAGE	DC110V
STARTS / HOUR	240 ST/H	INSULATION CLASS	F / H
GROOVE TYPE	UNDERCUT "U"	GROOVE β'	90°
IP PROTECTION	IP41	GROOVE γ	30°
POLE	32	WARRANTY	5 YEAR*

SPECIFICATION SHEET

MODEL	RATED VOLTAGE	CAPACITY	CABIN SPEED	RATED OUTPUT POWER	RATED CURRENT	RATED SPEED	FREQ.	SHEAVE DIA.	TORQUE	GROOVE DETAILS
	V	kg	m/s	kW	A	rpm	Hz	mm	N.m.	
IR1500	AC380	1500	1.00	9.80	25.0	85	22.6	Ø450	1103	10 × Ø10 × 16
IR1500	AC380	1500	1.25	12.3	25.0	106	28.3	Ø450	1103	10 × Ø10 × 16
IR1500	AC380	1500	1.50	14.7	34.0	127	34.0	Ø450	1103	10 × Ø10 × 16
IR1500	AC380	1500	1.75	17.2	34.0	149	39.6	Ø450	1103	10 × Ø10 × 16
IR1500	AC380	1500	2.00	19.6	40.0	170	45.3	Ø450	1103	10 × Ø10 × 16
IR1500	AC380	1500	2.50	24.5	51.0	212	56.6	Ø450	1103	10 × Ø10 × 16
IR2175	AC380	2175	1.00	14.2	36.0	85	22.6	Ø450	1600	10 × Ø10 × 16
IR2175	AC380	2175	1.25	17.8	36.0	106	28.3	Ø450	1600	10 × Ø10 × 16
IR2175	AC380	2175	1.50	21.3	50.0	127	34.0	Ø450	1600	10 × Ø10 × 16
IR2175	AC380	2175	1.75	24.9	50.0	149	39.6	Ø450	1600	10 × Ø10 × 16
IR2175	AC380	2175	2.00	28.5	58.0	170	45.3	Ø450	1600	10 × Ø10 × 16
IR2175	AC380	2175	2.50	35.6	74.0	212	56.6	Ø450	1600	10 × Ø10 × 16



BELT DRIVE SERIES BD450-1088

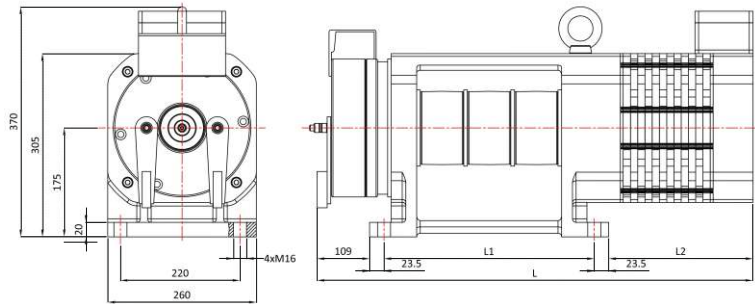
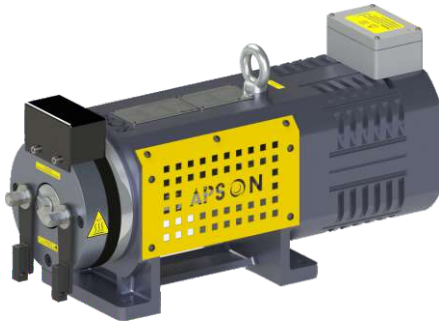

BELT DRIVE PERMANENT MAGNET SYNCHRONOUS ELEVATOR GEARLESS TRACTION MACHINE

ROPING	2:1	STATIC LOAD	250 kg
BALANCING	50%	MACHINE WEIGHT	150 kg*
DUTY CYCLE	S5-40%	BRAKE VOLTAGE	DC110V
STARTS / HOUR	180 ST/H	INSULATION CLASS	F / H
GROOVE TYPE	TAPPER	GROOVE β'	N/A
IP PROTECTION	IP41	GROOVE γ	N/A
POLE	24	WARRANTY	5 YEAR*

SPECIFICATION SHEET

MODEL	RATED VOLTAGE	CAPACITY kg	CABIN SPEED m/s	RATED OUTPUT POWER kW	RATED CURRENT A	RATED SPEED rpm	FREQ. Hz	SHEAVE DIA. mm	TORQUE N.m.	GROOVE DETAILS	MACHINE DIMENSION		
	V										L	L1	L2
BD450	AC380	450	0.50	1.50	4.00	191	38.2	Ø100	75	2 x 60	551	280	115
BD450	AC380	450	1.00	3.00	8.00	382	76.4	Ø100	75	2 x 60	551	280	115
BD680	AC380	680	0.50	2.25	7.00	191	38.2	Ø100	100	3 x 60	601	280	165
BD680	AC380	680	1.00	4.50	14.0	382	76.4	Ø100	100	3 x 60	601	280	165
BD1088	AC380	1088	0.50	3.50	8.50	191	38.2	Ø100	173	4 x 60	716	345	215
BD1088	AC380	1088	1.00	6.90	17.0	382	76.4	Ø100	173	4 x 60	716	345	215



OR SERIES OR1088-1500

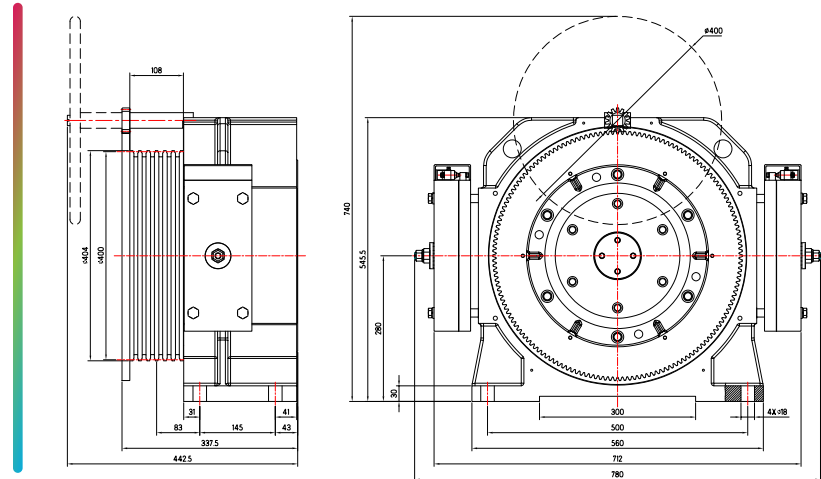
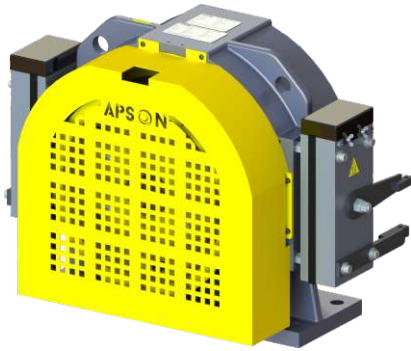

OUTER ROTOR PERMANENT MAGNET SYNCHRONOUS ELEVATOR GEARLESS TRACTION MACHINE

ROPING	2:1	STATIC LOAD	4500 kg
BALANCING	50%	MACHINE WEIGHT	360 kg*
DUTY CYCLE	S5-40%	BRAKE VOLTAGE	DC110V
STARTS / HOUR	240 ST/H	INSULATION CLASS	F / H
GROOVE TYPE	UNDERCUT "U"	GROOVE β'	90°
IP PROTECTION	IP41	GROOVE γ	30°
POLE	32	WARRANTY	5 YEAR*

SPECIFICATION SHEET

MODEL	RATED VOLTAGE	CAPACITY	CABIN SPEED	RATED OUTPUT POWER	RATED CURRENT	RATED SPEED	FREQ.	SHEAVE DIA.	TORQUE	GROOVE DETAILS
	V	kg	m/s	kW	A	rpm	Hz	mm	N.m.	
OR1088	AC380	1088	1.00	7.40	17.0	95	25.5	Ø400	740	6 × Ø10 × 16
OR1088	AC380	1088	1.25	9.40	19.0	119	31.8	Ø400	740	6 × Ø10 × 16
OR1088	AC380	1088	1.50	11.1	25.0	143	38.2	Ø400	740	6 × Ø10 × 16
OR1088	AC380	1088	1.75	13.4	27.0	167	44.6	Ø400	740	6 × Ø10 × 16
OR1088	AC380	1088	2.00	15.4	29.0	191	50.9	Ø400	740	6 × Ø10 × 16
OR1088	AC380	1088	2.50	19.4	38.0	239	63.7	Ø400	740	6 × Ø10 × 16
OR1360	AC380	1360	1.00	8.00	22.0	95	25.5	Ø400	800	6 × Ø10 × 16
OR1360	AC380	1360	1.25	10.0	24.0	119	31.8	Ø400	800	6 × Ø10 × 16
OR1360	AC380	1360	1.50	12.0	30.0	143	38.2	Ø400	800	6 × Ø10 × 16
OR1360	AC380	1360	1.75	14.0	32.0	167	44.6	Ø400	800	6 × Ø10 × 16
OR1360	AC380	1360	2.00	16.0	34.0	191	50.9	Ø400	800	6 × Ø10 × 16
OR1360	AC380	1360	2.50	20.0	43.0	239	63.7	Ø400	800	6 × Ø10 × 16
OR1500	AC380	1500	0.50	4.30	12.0	48	12.8	Ø400	865	6 × Ø10 × 16
OR1500	AC380	1500	1.00	8.60	23.0	95	25.5	Ø400	865	6 × Ø10 × 16
OR1500	AC380	1500	1.25	10.8	26.0	119	31.8	Ø400	865	6 × Ø10 × 16
OR1500	AC380	1500	1.50	13.0	32.0	143	38.2	Ø400	865	6 × Ø10 × 16
OR1500	AC380	1500	1.75	15.1	37.0	167	44.6	Ø400	865	6 × Ø10 × 16



OR SERIES OR1768-2175

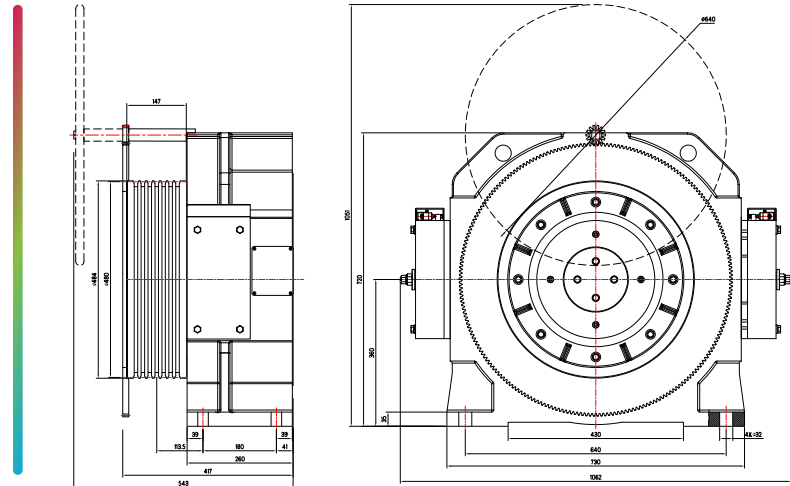
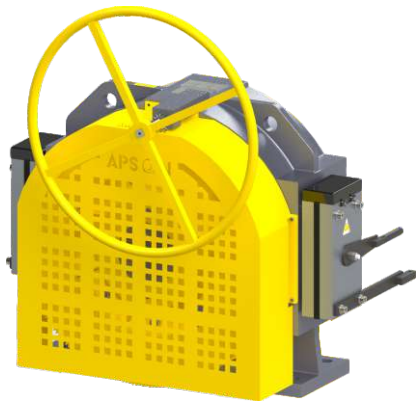

OUTER ROTOR PERMANENT MAGNET SYNCHRONOUS ELEVATOR GEARLESS TRACTION MACHINE

ROPING	2:1	STATIC LOAD	10,000 kg
BALANCING	50%	MACHINE WEIGHT	700 kg*
DUTY CYCLE	S5-40%	BRAKE VOLTAGE	DC110V
STARTS / HOUR	240 ST/H	INSULATION CLASS	F / H
GROOVE TYPE	UNDERCUT "U"	GROOVE β'	90°
IP PROTECTION	IP41	GROOVE γ	30°
POLE	48	WARRANTY	5 YEAR*

SPECIFICATION SHEET

MODEL	RATED VOLTAGE	CAPACITY	CABIN SPEED	RATED OUTPUT POWER	RATED CURRENT	RATED SPEED	FREQ.	SHEAVE DIA.	TORQUE	GROOVE DETAILS
	V	kg	m/s	kW	A	rpm	Hz	mm	N.m.	
OR1768	AC380	1768	0.50	5.60	14.0	40	15.9	Ø480	1345	9 × Ø10 × 15
OR1768	AC380	1768	1.00	11.2	27.0	80	31.8	Ø480	1345	9 × Ø10 × 15
OR1768	AC380	1768	1.25	14.0	34.0	99	39.8	Ø480	1345	9 × Ø10 × 15
OR1768	AC380	1768	1.50	16.8	41.0	119	47.7	Ø480	1345	9 × Ø10 × 15
OR1768	AC380	1768	1.75	19.6	48.0	139	55.7	Ø480	1345	9 × Ø10 × 15
OR1768	AC380	1768	2.00	22.4	55.0	159	63.7	Ø480	1345	9 × Ø10 × 15
OR1768	AC380	1768	2.50	28.0	69.0	199	79.6	Ø480	1345	9 × Ø10 × 15
OR2175	AC380	2175	0.50	6.90	19.5	40	15.9	Ø480	1655	9 × Ø10 × 15
OR2175	AC380	2175	1.00	13.8	39.0	80	31.8	Ø480	1655	9 × Ø10 × 15
OR2175	AC380	2175	1.25	17.2	39.0	99	39.8	Ø480	1655	9 × Ø10 × 15
OR2175	AC380	2175	1.50	20.7	53.0	119	47.7	Ø480	1655	9 × Ø10 × 15
OR2175	AC380	2175	1.75	24.1	53.0	139	55.7	Ø480	1655	9 × Ø10 × 15
OR2175	AC380	2175	2.00	27.6	60.0	159	63.7	Ø480	1655	9 × Ø10 × 15
OR2175	AC380	2175	2.50	34.5	70.0	199	79.6	Ø480	1655	9 × Ø10 × 15



OR SERIES OR2700-3000

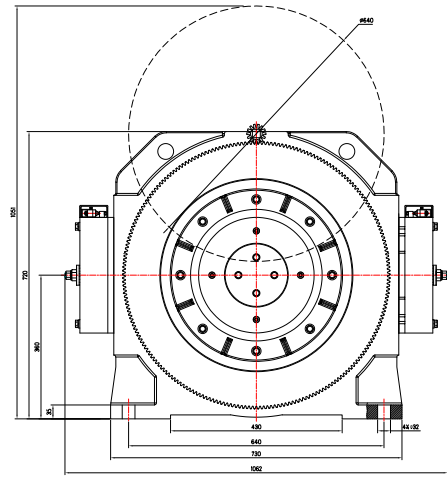
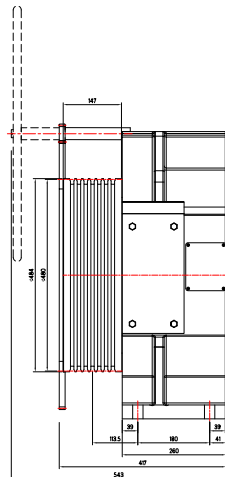
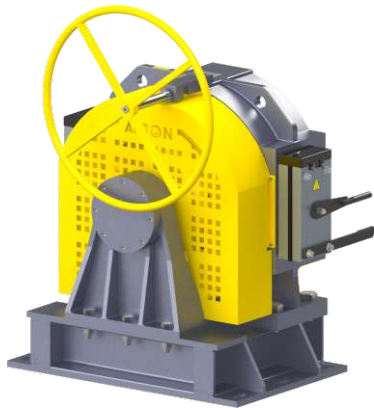

OUTER ROTOR PERMANENT MAGNET SYNCHRONOUS ELEVATOR GEARLESS TRACTION MACHINE

ROPING	2:1	STATIC LOAD	10,000 kg
BALANCING	50%	MACHINE WEIGHT	700 kg*
DUTY CYCLE	S5-40%	BRAKE VOLTAGE	DC110V
STARTS / HOUR	240 ST/H	INSULATION CLASS	F / H
GROOVE TYPE	UNDERCUT "U"	GROOVE β'	90°
IP PROTECTION	IP41	GROOVE γ	30°
POLE	48	WARRANTY	5 YEAR*

SPECIFICATION SHEET

MODEL	RATED VOLTAGE	CAPACITY	CABIN SPEED	RATED OUTPUT POWER	RATED CURRENT	RATED SPEED	FREQ.	SHEAVE DIA.	TORQUE	GROOVE DETAILS
	V	kg	m/s	kW	A	rpm	Hz	mm	N.m.	
OR2700	AC380	2700	0.50	8.60	24.00	40	15.9	Ø480	2053	9 × Ø10 × 15
OR2700	AC380	2700	1.00	17.1	47.00	80	31.8	Ø480	2053	9 × Ø10 × 15
OR2700	AC380	2700	1.25	21.4	47.00	99	39.8	Ø480	2053	9 × Ø10 × 15
OR2700	AC380	2700	1.50	25.7	63.00	119	47.7	Ø480	2053	9 × Ø10 × 15
OR2700	AC380	2700	1.75	29.9	63.00	139	55.7	Ø480	2053	9 × Ø10 × 15
OR2700	AC380	2700	2.00	34.2	72.00	159	63.7	Ø480	2053	9 × Ø10 × 15
OR2700	AC380	2700	2.50	42.8	90.00	199	79.6	Ø480	2053	9 × Ø10 × 15
OR3000	AC380	3000	0.50	8.50	26.00	40	15.9	Ø480	2283	9 × Ø10 × 15
OR3000	AC380	3000	1.00	19.0	52.00	80	31.8	Ø480	2283	9 × Ø10 × 15
OR3000	AC380	3000	1.25	23.8	52.00	99	39.8	Ø480	2283	9 × Ø10 × 15
OR3000	AC380	3000	1.50	28.5	70.00	119	47.7	Ø480	2283	9 × Ø10 × 15
OR3000	AC380	3000	1.75	33.3	70.00	139	55.7	Ø480	2283	9 × Ø10 × 15
OR3000	AC380	3000	2.00	38.0	80.00	159	63.7	Ø480	2283	9 × Ø10 × 15
OR3000	AC380	3000	2.50	47.6	100.0	199	79.6	Ø480	2283	9 × Ø10 × 15





HEAD QUARTER

APSON EMPIRE, SURVEY NO. 7-2-1/2, NH. 47, AHMEDBAD – INDORE HIGHWAY,
OPP. INDIAN OIL PETROL PUMP, AT - MIRZAPUR, TALUKA KATHALAL,
DIS. – KHEDA, GUJARAT – 387630

REGISTERED OFFICE

PLOT NO. C1-539, ROAD NO. 41, NR. ODHAV POST OFFICE,
G.I.D.C. ODHAV, AHMEDABAD – 382415

E: sales@apson.co.in | M: +91-9924866671

PROUD MEMBER

